

# MultiCo SFP-1000A 20km DDM/ SFP-1000B 20km DDM

## Features:

- ✧ Single Mode bi-directional Transmission
- ✧ SFP Multi-source Package with SC Receptacle
- ✧ Up to 1.25Gb/s Data Links
- ✧ Hot-Pluggable Capability
- ✧ Single +3.3V Power Supply
- ✧ Isolation > 30dB, Cross Talk < -45dB
- ✧ Metal Enclosure, Excellent EMI & ESD Protection
- ✧ Extended Temperature Range  $-40^{\circ}\text{C} \sim +85^{\circ}\text{C}$
- ✧ Monitoring interface compliant with SFF-8472
- ✧ Real time monitoring of:
  - Transmitted optical power
  - Received optical power
  - Laser bias current
  - Temperature
  - Supply voltage
- ✧ Compliant with Bellcore TA-NWT-000983
- ✧ Eye Safety Designed to Meet Laser Class1, Compliant with IEC60825-1
- ✧ Compliant with Specifications for IEEE802.3
- ✧ RoHS Compliant

## Applications:

- ✧ Gigabit Ethernet
- ✧ Fiber Channel
- ✧ Switch to Switch interface
- ✧ Other Optical Links

## Specification:

### ● Electrical and Optical Characteristics: (Condition: $T_a = T_{OP}$ )

Parameter	Symbol	Min.	Typical	Max.	Unit
Transmitter Differential Input Voltage	+/-TX_DAT	200		2400	mV p-p
Supply Current	I <sub>CC</sub>		200	250	mA
Tx_Disable Input Voltage – Low	V <sub>IL</sub>	0		0.8	V
Tx_Disable Input Voltage – High	V <sub>IH</sub>	2.0		V <sub>CC</sub>	V
Tx_Fault Output Voltage – Low	V <sub>OL</sub>	0		0.8	V
Tx_Fault Output Voltage – High	V <sub>OH</sub>	2.0		V <sub>CC</sub>	V
Receiver Differential Output Voltage	+/-RX_DAT	600		1400	mV p-p
Rx_LOS Output Voltage- Low	V <sub>OL</sub>	0		0.8	V
Rx_LOS Output Voltage- High	V <sub>OH</sub>	2.0		V <sub>CC</sub>	V

**Transmitter SFP-1000A 20km DDM**

Parameter	Symbol	Min.	Typical	Max.	Unit
Data Rate	B	-	1250	-	Mb/s
Centre Wavelength	$\lambda_c$	1260	1310	1360	nm
Output Spectral Width	$\square\lambda(\text{RMS})$	-	-	5	nm
Average Output Power	$P_o$	-9.5	-	-3	dBm
Extinction Ratio	E.R.	9	-	-	dB
Data Input Voltage-High	$V_{IHS}$	$V_{cc}-1.16$	-	$V_{cc}-0.89$	V
Data Input Voltage -Low	$V_{ILS}$	$V_{cc}-1.82$	-	$V_{cc}-1.48$	V
Supply Current	$I_{CC}$	-	90	110	mA
Output Optical Eye	Compliant with ITU-T G.957				

**Receiver SFP-1000A 20km DDM**

Parameter	Symbol	Min.	Typical	Max.	Unit
Receive Sensitivity	$P_{min}$	-	-	-22	dBm
Maximum Input Power	$P_{MAX}$	-3	-	-	dBm
Signal Detection-Asserted	$P_{H-L}$	-35	-	-	dBm
Signal Detection-Deserted	$P_{L-H}$	-	-	-23	dBm
Output High Voltage	$V_{OH}$	$V_{cc}-1.03$	-	$V_{cc}-0.89$	V
Output Low Voltage	$V_{OL}$	$V_{cc}-1.82$	-	$V_{cc}-1.63$	V
Operating Wavelength	$\lambda_c$	1500	1550	1600	nm
Supply Current	$I_{CC}$	-	80	110	mA

**Transmitter SFP-1000B 20km DDM**

Parameter	Symbol	Min.	Typical	Max.	Unit
Data Rate	B	-	1250	-	Mb/s
Centre Wavelength	$\lambda_c$	1500	1550	1600	nm
Output Spectral Width	$\square\lambda(\text{RMS})$	-	-	5	nm
Average Output Power	$P_o$	-9.5	-	-3	dBm
Extinction Ratio	E.R.	9	-	-	dB
Data Input Voltage-High	$V_{IHS}$	$V_{cc}-1.16$	-	$V_{cc}-0.89$	V
Data Input Voltage -Low	$V_{ILS}$	$V_{cc}-1.82$	-	$V_{cc}-1.48$	V
Supply Current	$I_{CC}$	-	90	110	mA
Output Optical Eye	Compliant with ITU-T G.957				

**Receiver SFP-1000B 20km DDM**

Parameter	Symbol	Min.	Typical	Max.	Unit
Receive Sensitivity	$P_{min}$	-	-	-22	dBm
Maximum Input Power	$P_{MAX}$	-3	-	-	dBm
Signal Detection-Asserted	$P_{H-L}$	-35	-	-	dBm
Signal Detection-Deserted	$P_{L-H}$	-	-	-23	dBm
Output High Voltage	$V_{OH}$	$V_{cc}-1.03$	-	$V_{cc}-0.89$	V
Output Low Voltage	$V_{OL}$	$V_{cc}-1.82$	-	$V_{cc}-1.63$	V
Operating Wavelength	$\lambda_c$	1260	1310	1360	nm
Supply Current	$I_{CC}$	-	80	110	mA

● **Absolute Maximum Ratings: ( $T_C=25^\circ$ )**

Parameter	Symbol	Min.	Max.	Unit
Storage Temperature	$T_{ST}$	-40	+85	$^\circ$
Operating Temperature	$T_{IP}$	-40	+85	$^\circ$
Input Voltage	$T_{CC}$	0	+5	V

● **Recommended Operating Environment:**

Parameter	Symbol	Min.	Typical	Max.	Unit
Supply Voltage	$V_{CC}$	+3.0	+3.3	+3.6	V
Operating Temperature	$T_{OP}$	-40	-	+85	$^\circ$

● **Timing Characteristics:**

Parameter	Symbol	Min.	Typical	Max.	Unit
TX_DISABLE Assert Time	$t_{off}$		3	10	usec
TX_DISABLE Negate Time	$t_{on}$		0.5	1	msec
Time to Initialize Include Reset of TX_FAULT	$t_{int}$		30	300	msec
TX_FAULT from Fault to Assertion	$t_{fault}$		20	100	usec
TX_DISBEL Time to Start Reset	$t_{reset}$	10			usec
Receiver Loss of Signal Assert Time (Off to On)	$T_{A,RX\_LOS}$			100	usec
Receiver Loss of Signal Assert Time (On to Off)	$T_{d,RX\_LOS}$			100	usec

● **Digital Diagnostic Monitor Characteristics:**

Parameter	Min.	Unit
Tx Output Power Accuracy	$\pm 3.0$	dBm
Rx Input Power Accuracy	$\pm 3.0$	dBm
Laser Bias Current Accuracy	$\pm 1.0$	%
Transceiver Internal Temperature Accuracy	$\pm 3.0$	$^\circ C$
Transceiver Internal Supply Voltage Accuracy	$\pm 0.1$	V

**Pin Assignment:**

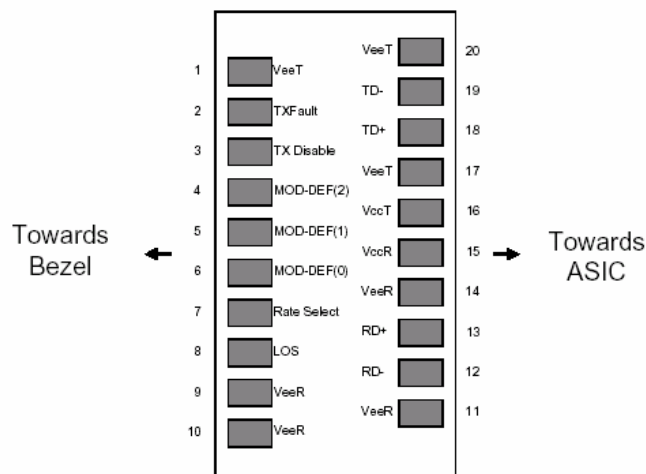

**Pin out of Connector Block on Host Board**

**Pin Description:**

Pin	Signal Name	Description	Plug Seq.	Notes
-----	-------------	-------------	-----------	-------

1	V <sub>EET</sub>	Transmitter Ground	1	
2	T <sub>FAULT</sub>	Transmitter Fault Indication	3	Note1
3	T <sub>DIS</sub>	Transmitter Disable	3	Note2, Module disables on high or open
4	MOD_DEF(2)	SDA Serial Data Signal	3	Note3, 2 wire serial ID interface
5	MOD_DEF(1)	SCL Serial Clock Signal	3	Note3, 2 wire serial ID interface
6	MOD_DEF(0)	TTL Low	3	Note3, Grounded in Module
7	Rate Select	Select between full or reduced receiver bandwidth	3	NO connection required, Low or Open-reduced bandwidth, High-full bandwidth
8	LOS	Loss of Signal indication, Logic 0 indicate normal operation	3	Note 5
9	V <sub>EER</sub>	Receiver ground	1	Note 6
10	V <sub>EER</sub>	Receiver ground	1	Note 6
11	V <sub>EER</sub>	Receiver ground	1	Note 6
12	RX <sub>-</sub>	Receiver Data Bar, Differential PECL, ac coupled	3	Note 7
13	RX <sub>+</sub>	Receiver Data, Differential PECL, ac coupled	3	Note 7
14	V <sub>EER</sub>	Receiver ground	1	Note 6
15	V <sub>CCR</sub>	Receiver Power Supply	2	3.3V <sub>±</sub> 5%,Note 8
16	V <sub>CCT</sub>	Transmitter Power Supply	2	3.3V <sub>±</sub> 5%,Note 8
17	V <sub>EET</sub>	Transmitter Ground	1	Note 6
18	TX <sub>+</sub>	Receiver Data, Differential PECL, ac coupled	3	Note 9
19	TX <sub>-</sub>	Receiver Data Bar, Differential PECL, ac coupled	3	Note 9
20	V <sub>EET</sub>	Transmitter Ground	1	Note 6

### Notes:

Plug Seq.: Pin engagement sequence during hot plugging.

1) TX Fault is an open collector/drain output, which should be pulled up with a 4.7K – 10K resistor on the host board. Pull up voltage between 2.0V and V<sub>ccT</sub>, R+0.3V. When high, output indicates a laser fault of some kind. Low indicates normal operation. In the low state, the output will be pulled to < 0.8V.

2) TX disable is an input that is used to shut down the transmitter optical output. It is pulled up within the module with a 4.7 K resistor. Its states are:

Low (0 to 0.8V): Transmitter on

(>0.8, < 2.0V): Undefined

High (2.0 to 3.465V): Transmitter Disabled

Open: Transmitter Disabled

3) Mod-Def 0,1,2. These are the module definition pins. They should be pulled up with a 4.7K to 10K resistor on the host board.

The pull-up voltage shall be V<sub>ccT</sub> or V<sub>ccR</sub>

Mod-Def 0 is grounded by the module to indicate that the module is present

Mod-Def 1 is the clock line of two wire serial interface for serial ID

Mod-Def 2 is the data line of two wire serial interface for serial ID

4) This is an optional input used to control the receiver bandwidth for compatibility with multiple data rates (most likely Fibre Channel 1x and 2x Rates). If implemented, the input will be internally pulled down with > 30k resistor. The input states are:

Low (0 to 0.8V): Reduced Bandwidth

(>0.8, < 2.0V): Undefined

High (2.0 to 3.465V): Full Bandwidth

Open: Reduced Bandwidth

5) LOS (Loss of Signal) is an open collector/drain output, which should be pulled up with a 4.7K to 10K resistor. Pull up voltage between 2.0V and V<sub>ccT</sub>, R+0.3V. When high, this output indicates the received optical power is below the worst-case receiver sensitivity (as defined by the standard in use). Low indicates normal operation. In the low state, the output will be pulled to <0.8V.

- 6) VeeR and VeeT may be internally connected within the SFP module.
- 7) RD-/+ : These are the differential receiver outputs. They are AC coupled 100 differential lines which should be terminated with 100  $\Omega$  (differential) at the user SERDES. The AC coupling is done inside the module and is thus not required on the host board. The voltage swing on these lines will be between 370 and 2000 mV differential (185 to 1000 mV single ended) when properly terminated.
- 8) VccR and VccT are the receiver and transmitter power supplies. They are defined as 3.3V  $\pm$ 5% at the SFP connector pin. Maximum supply current is 300 mA. Recommended host board power supply filtering is shown below. Inductors with DC resistance of less than 1 $\Omega$  should be used in order to maintain the required voltage at the SFP input pin with 3.3V supply voltage. When the recommended supply filtering network is used, hot plugging of the SFP transceiver module will result in an inrush current of no more than 30 mA greater than the steady state value. VccR and VccT may be internally connected within the SFP transceiver module.
- 9) TD-/+ : These are the differential transmitter inputs. They are AC-coupled, differential lines with 100 differential termination inside the module. The AC coupling is done inside the module and is thus not required on the host board. The inputs will accept differential swings of 500 to 2400 mV (250 to 1200 mV single-ended), though it is recommended that values between 500 and 1200 mV differential (250 to 600 mV single-ended) be used for best EMI performance.

### Block Diagram of Transceiver:

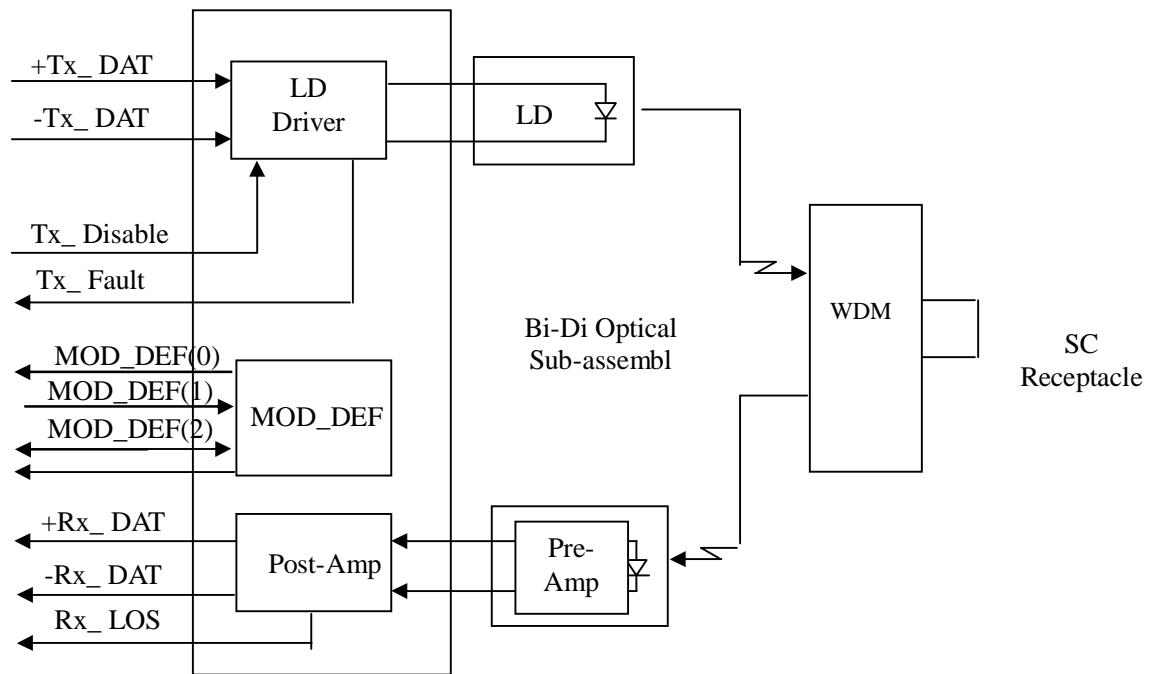

**Mechanical Dimensions:**

